

BUREAU D'ÉTUDE ÉLECTRONIQUE AUTOMOBILE - DETAILS OF PROGRAM PMSM_TGN002_CDE_UF

Alexandre Boyer

alexandre.boyer@insa-toulouse.fr

November 2020

Brief description

- ▶ **Purpose:** demonstration of **U/f command** of a PMSM motor (TG Drive TGN2-0028-30-24), with MPC5744P MCU, GD3000 gate driver and PGA411 resolver interface.
- ▶ The program supports two modes: either the motor is simulated (for software debug purpose) or the motor is connected.
- ▶ Pushing switch1 activates or stops the motor rotation.
- ▶ The speed rotation increases according to a ramp profile (+0.25 RPM/ms).
- ▶ The command is based on a 120 μ s PWM signal, which synchronizes the update of the next PWM duty cycle (**fast loop**) and speed command (**slow loop**).
- ▶ Current on phases A, B, C are acquired every 120 μ s. Rotor speed and position are acquired every 1.20 ms. They can be transmitted to host PC by **Freemaster** for validation/instrumentation purpose.
- ▶ All the numbers are in 32-bit float format and mathematical operations are based on functions of **AMMCLIB** libraries.

HW/SW block diagram

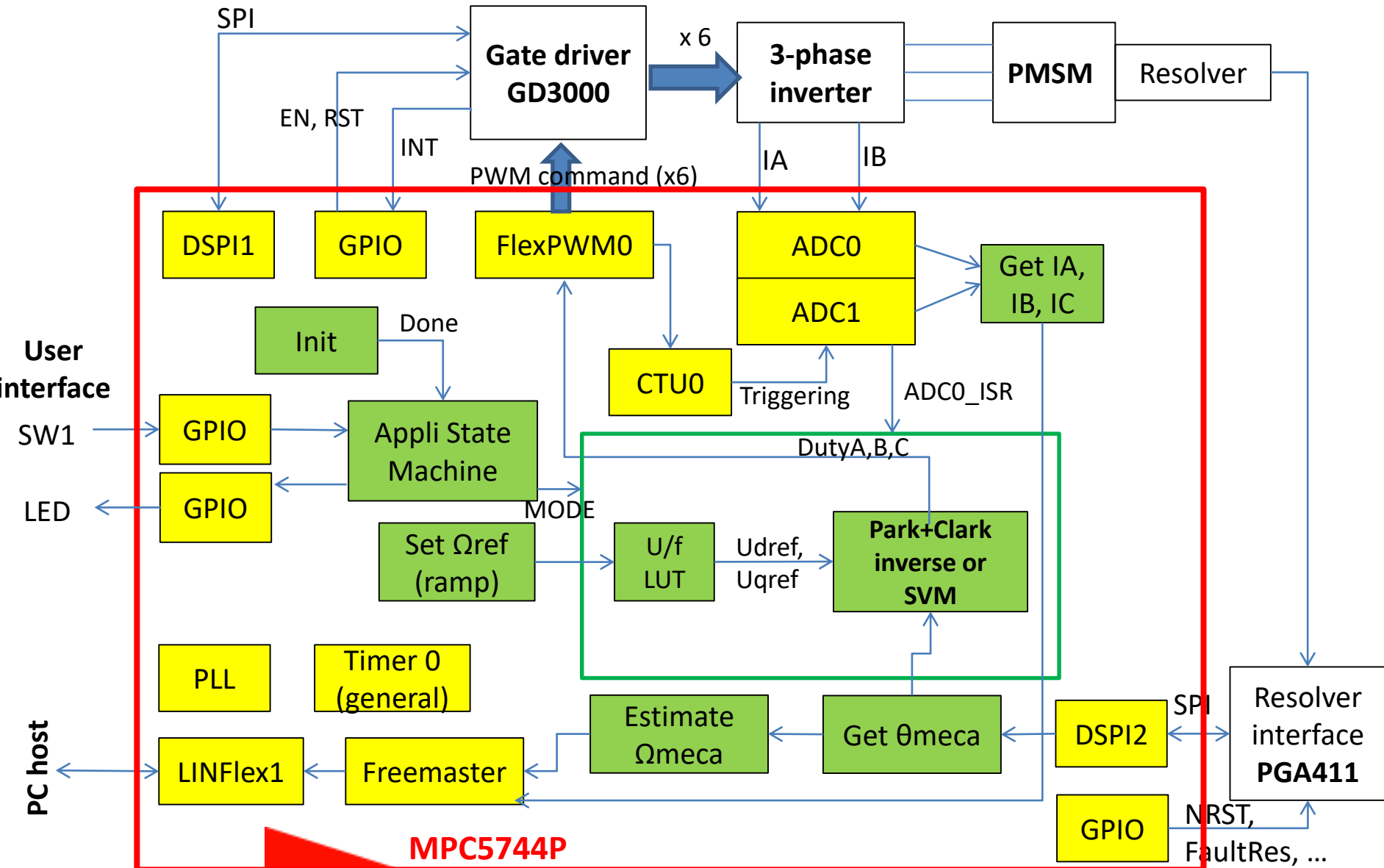

Software flow chart – Overall view

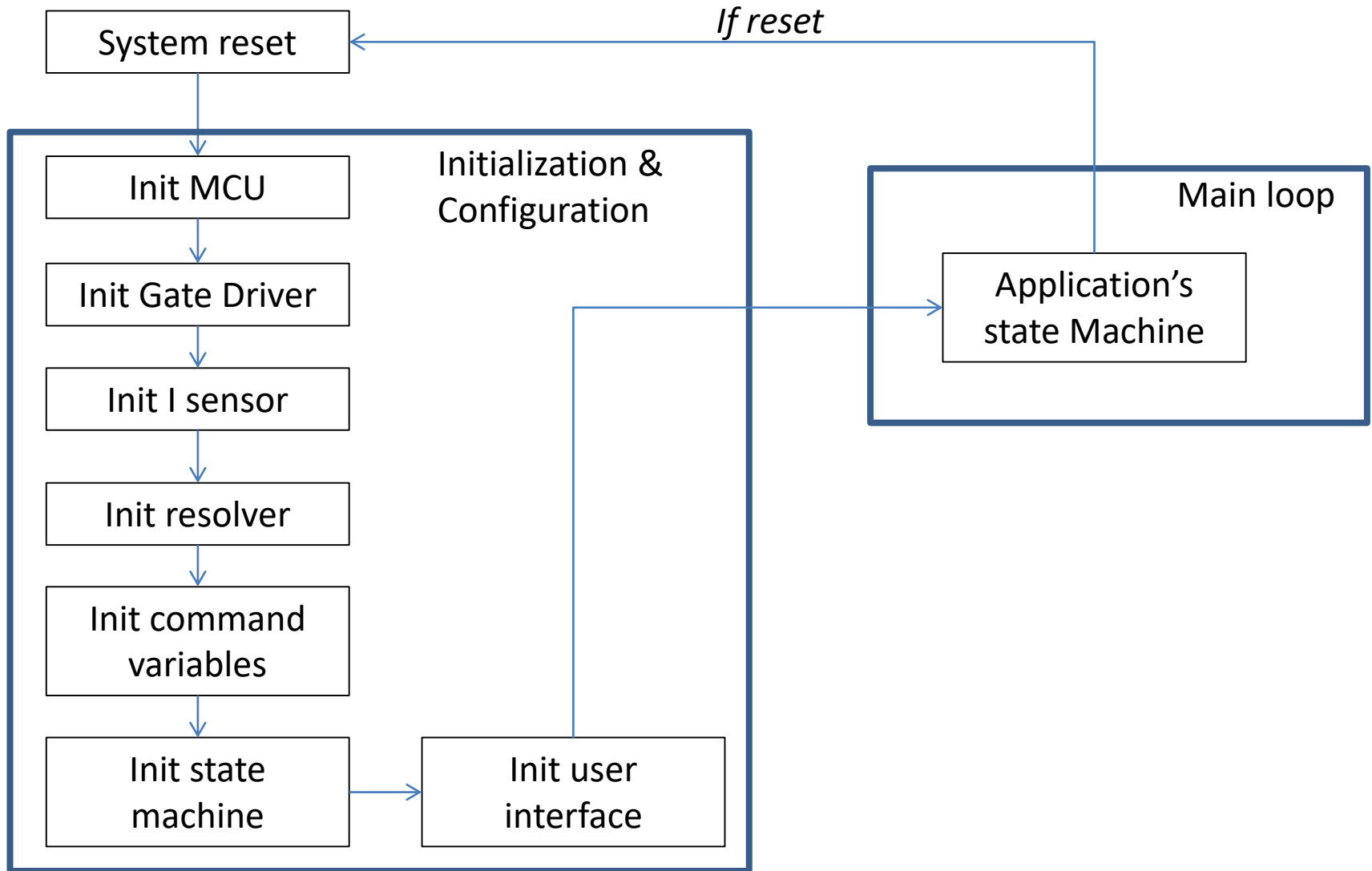

Software flow chart – Normal vs. stop mode

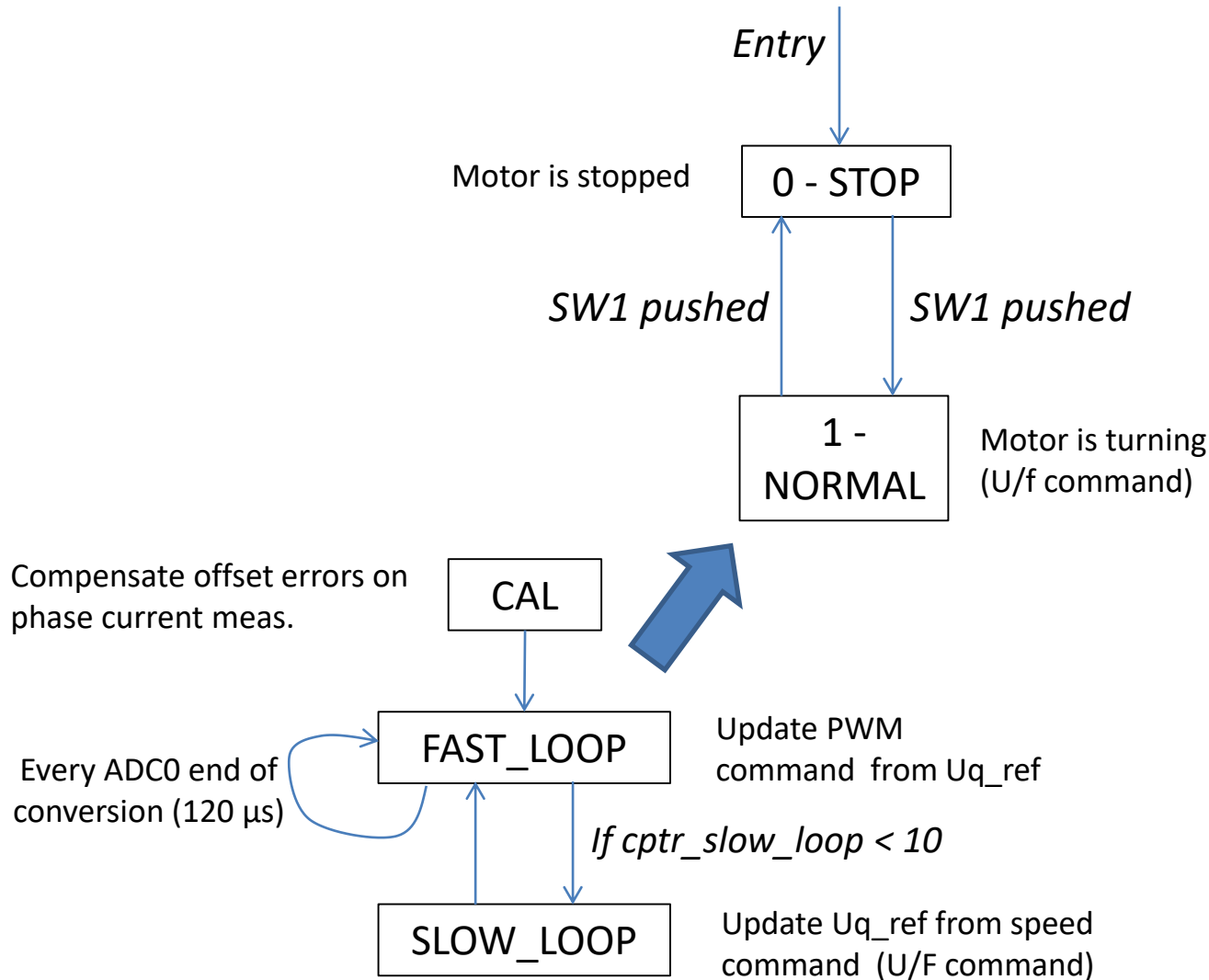

Software flow chart – NORMAL Mode – Fast loop

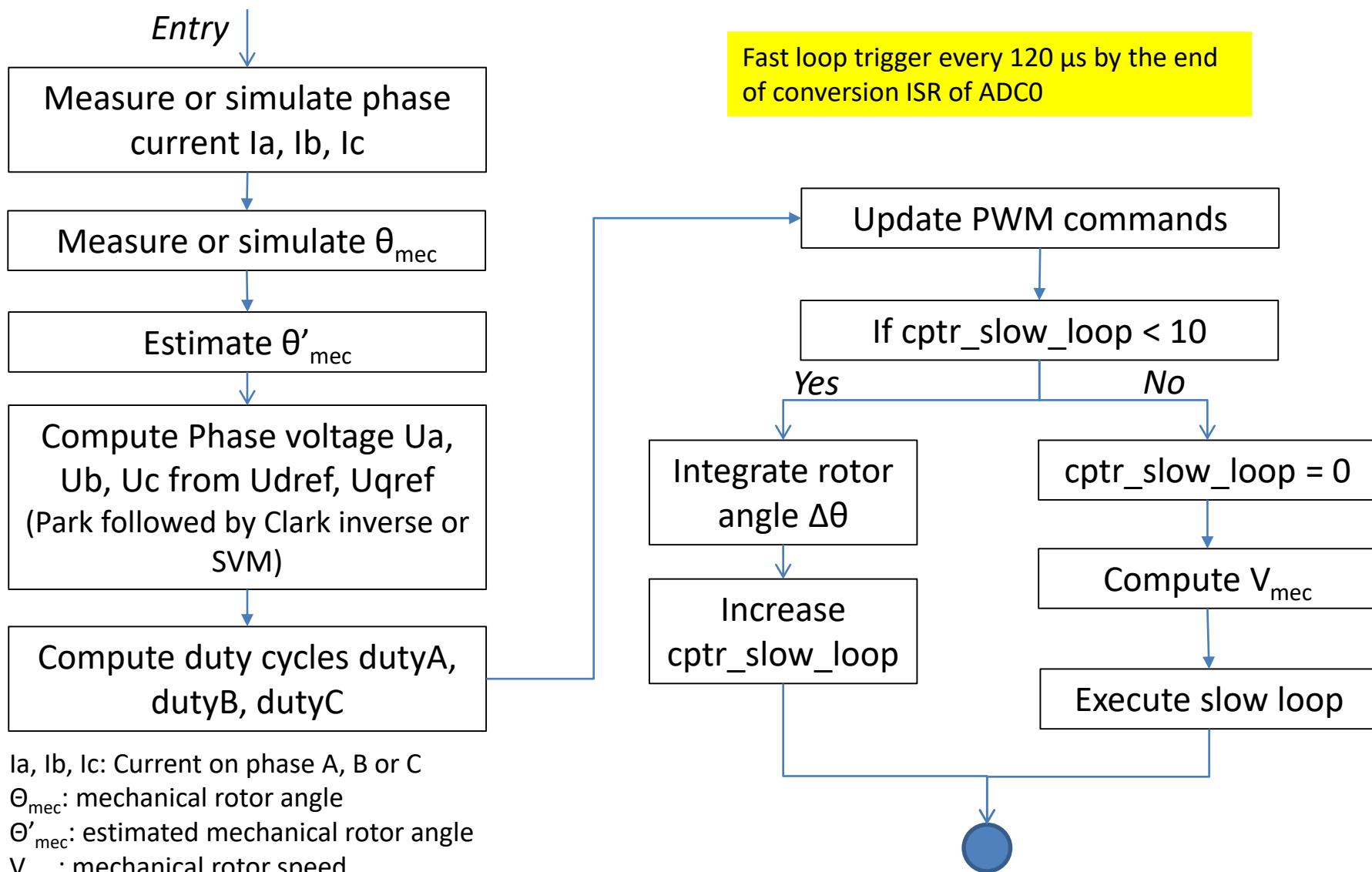

Fast loop trigger every 120 μ s by the end of conversion ISR of ADC0

I_a, I_b, I_c : Current on phase A, B or C
 θ_{mec} : mechanical rotor angle
 θ'_{mec} : estimated mechanical rotor angle
 V_{mec} : mechanical rotor speed
 SVM = standard Space Vector Modulation

Software flow chart – Slow loop

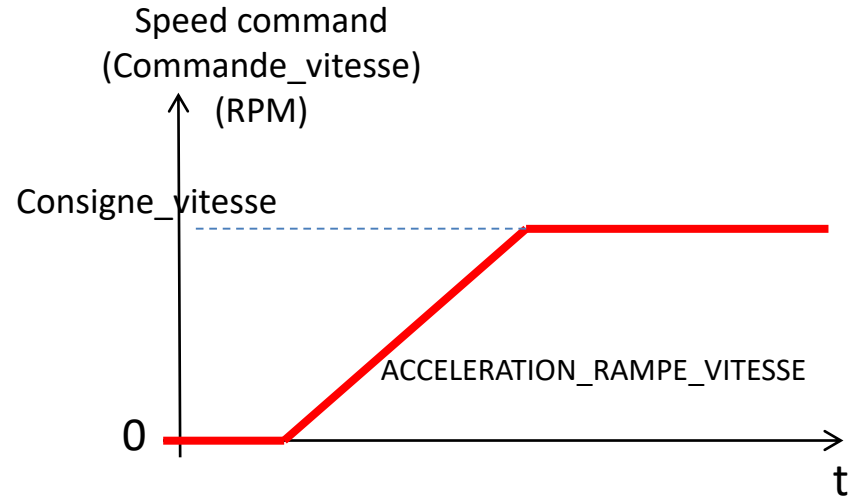
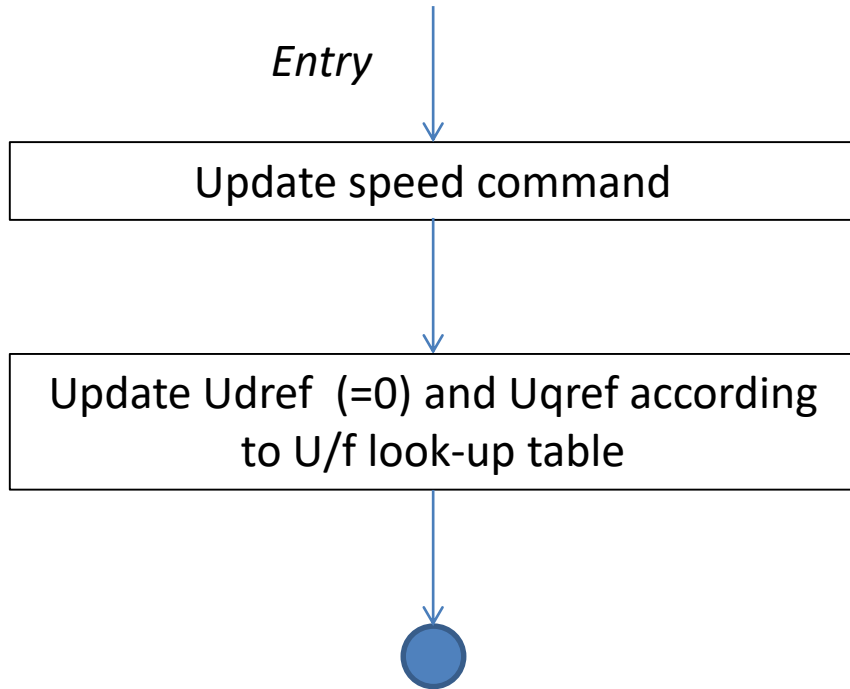

Software flow chart – Mode CAL

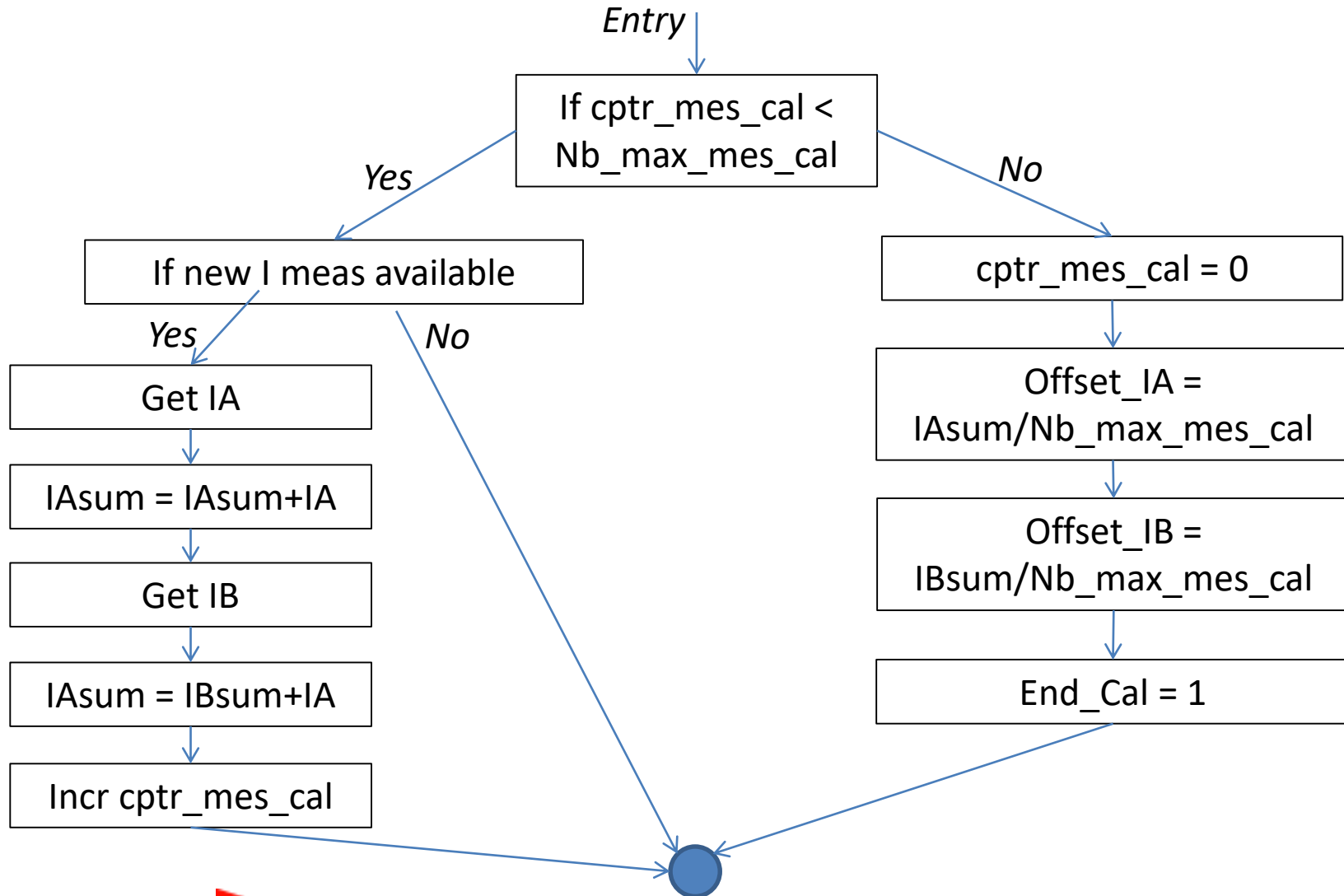

Software architecture

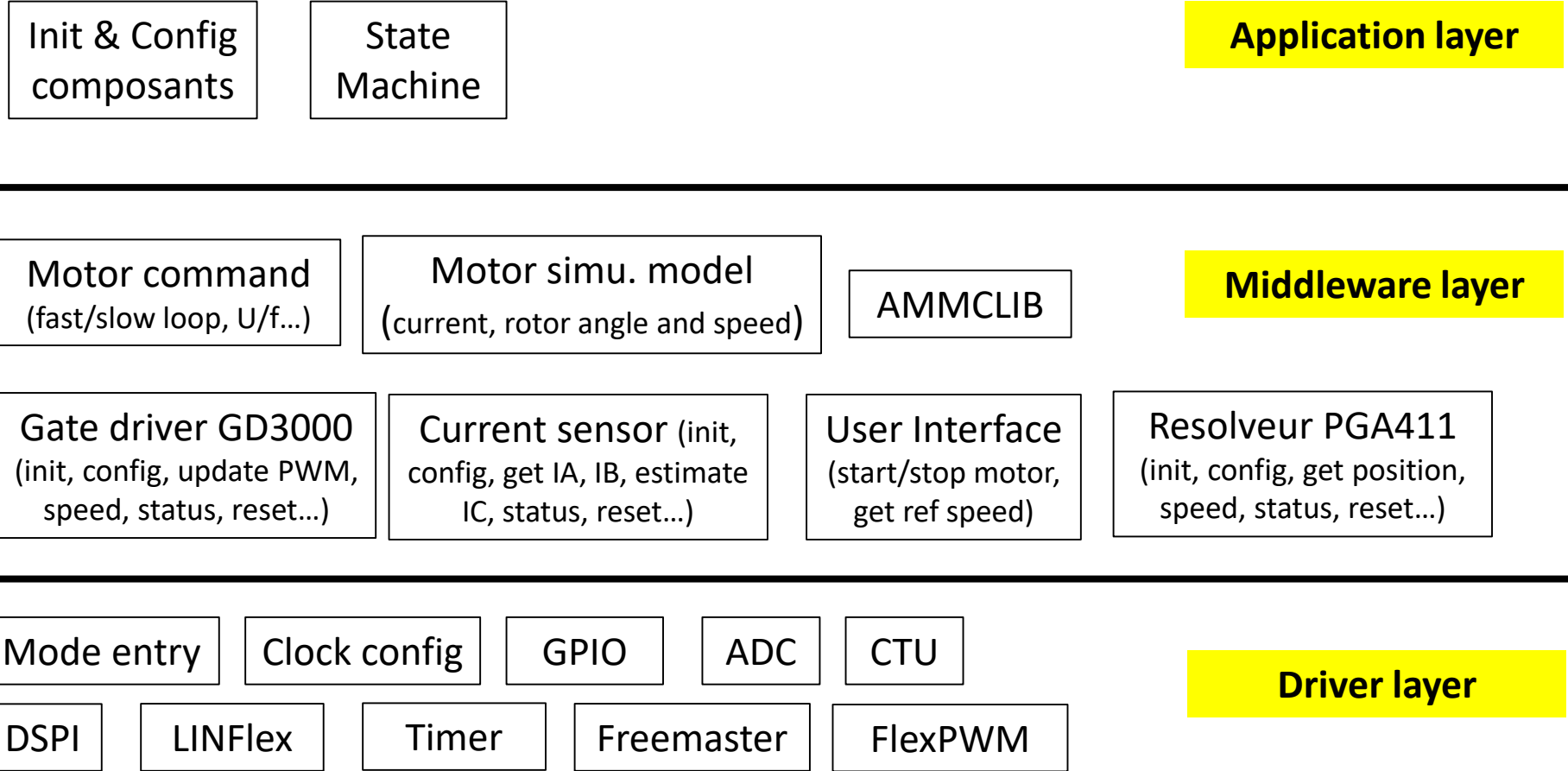

Software architecture

ClockConfig.c/.h	Initialization of clock buses and oscillators
Cmd_moteur.c/.h	Functions for the motor command (e.g. fast/slow loop execution, U/f look-up table, ...)
Config_eDMA.c/.h	Configuration of DMA transfer
ConfigADC.c/.h	Configuration of analog-to-digital converters (for phase current acquisition)
ConfigCTU.c/.h	Configuration of Cross Triggering Unit (synchronization between PWM and ADC)
ConfigPIT.c/.h	Configuration of the Periodic Interrupt Timer
ConfigPWM.c/.h	Configuration of the phase PWM signals
Current_Sensor.c/.h	Configuration of current sensing chain and extraction of phase current
DSPI_Config.c.h	Configuration of SPI buses (MCU - gate driver and MCU – resolver interface)
gd3000.c	Configuration of gate driver GD3000, activation/deactivation of inverter command, diagnosis
ModeEntryAndConfig.c/.h	Configuration of MCU mode entry
Modele_moteur_virtuel.c/.h	Simulation model of PMSM
pga411.c/.h	Configuration of resolver interface PGA411, acquisition of rotor angle and speed, diagnosis
UARTConfig.c/.h	UART configuration (to use Freemaster)
User_Interface.c/.h	Configuration of the user interface